



The -hp- TV Monitor

MANY television engineers who have been associated with f-m broadcast stations have worked with the -hp- Model 335B f-m frequency monitor and modulation meter.¹ That the 335B was a successful design is indicated by the fact that it was used in more f-m stations than all other monitors combined. Among station personnel the monitor has been popular because it operated accurately for extended periods without adjustment.

The same design approach used in the 335B has been used in the new -hp- Model 335E aural and visual monitor for television stations. The 335E uses the pulse-counter type frequency meter that proved popular in the 335B because of its simplicity and stability. Like the f-m monitor, the TV monitor is small in size, being only 12 $\frac{1}{4}$ " high by relay rack width.

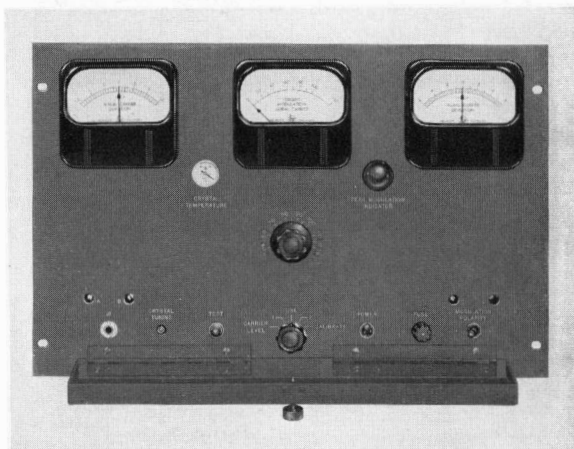

Fig. 1. -hp- Model 335E TV monitor measures aural and visual carrier deviations and percent aural modulation. The monitor includes such features as a pulse-counter type discriminator, full provision for remote lamp and meters, all operating controls located on front panel.

Three panel meters on the equipment monitor the frequencies of the visual and aural carriers, and the percent modulation on the aural carrier with 100% modulation equal to 25 kc deviation. All indications are presented simultaneously. The monitor can be used with any one of the TV channels in either the VHF or UHF bands. The circuit arrangement also accommodates stations that may have offset carriers. Full provision is made for the use of a remote over-modulation lamp as well as remote indicating meters. All operating adjustments can be made on the front panel of the monitor.

Although the 335E is primarily intended to indicate the percentage modulation of the aural carrier and to monitor the frequencies of both carriers, it is also valuable as an aid in making a number of other important measurements relating to the quality of the transmission. For example, the monitor is useful in measuring the f-m and a-m noise levels and in measuring the frequency response and distortion characteristics of the aural transmitter.

CIRCUIT ARRANGEMENT

A block diagram of the monitor circuit is shown in Fig. 2. The master oscillator is a cathode-coupled two-stage circuit which is controlled by an overtone type crystal operating in the 20-30 megacycle region. The crystal is mounted in a carefully-designed

¹N. B. Schrock and David Packard, "A Pulse Counter Type FM Station Monitor," Proceedings of the National Electronics Conference, Vol. 3, 1947.

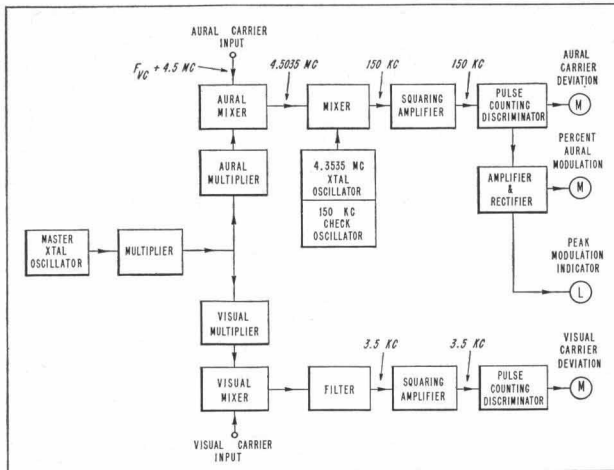

Fig. 2. Block diagram of -bp- Model 335E TV Monitor.

oven that controls temperature to within approximately 0.10°C . Oven temperature is indicated by a thermometer readable at the front panel. The oven thermostat is a long-life type in which a mercury column opens and closes the circuit between two fixed contacts. The oven heater circuit is connected directly across the power input connector so that the crystal temperature is always controlled as long as the instrument is connected to a power source.

The cathode-coupled type oscillator circuit has been selected because it allows series-resonant operation of the crystal. This arrangement has the advantage that stray capacities in the circuit have considerably less effect on the operating frequency than in the case of parallel-resonant crystal operation. As an indication of the quality of performance of the oscillator, variations in oscillator filament voltage from 5.7 to 6.9 volts affect the frequency of operation by only about 2-3 parts in 10^7 . In production instruments, however, the filament voltage for the master oscillator is regulated by means of a constant-voltage type transformer so that even this small voltage effect is reduced. Performance curves reflecting the long-time stability of the master oscillator in two typical production monitors are shown in Fig. 3.

The master oscillator is provided with a vernier tuning adjustment

Both the push-switch and the vernier control are available from the front panel of the instrument.

The master oscillator drives a tuned multiplier which feeds into the separate multipliers for the visual and aural channels of the monitor. In the visual channel the output of the first mixer is multiplied until it is 3.5 kc below the assigned visual carrier frequency of the station. The output of the visual mixer is then a frequency of 3.5 kc when the visual carrier is exactly at its assigned frequency.

The output of the visual channel mixer is passed through a filter that removes the 15,750 cps line frequency component in order to avoid the possibility of interaction of this frequency with the visual deviation meter circuit. The output waveform from the filter is squared and applied to the pulse counter circuit shown in basic form in Fig. 4. The pulse counter consists of a pair of switching tubes feeding a short time-constant RC network. A full-wave rectifier circuit and d-c meter are in-

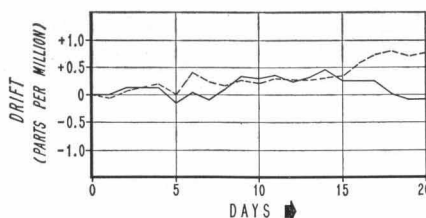

Fig. 3. Typical stability curves of master oscillator in two production monitors. Oscillator uses a cathode-coupled type circuit with series-resonant crystal.

for correcting long-time drift. In addition a push-switch minimizes the possibility of setting the master oscillator or transmitter oscillator so that the image frequency of the monitor is obtained.

incorporated into the network in such a way that the current charging the capacitors is passed through the meter.

When the square wave output of the switching tubes is applied to the network, the current charging the capacitors consists of pulses as indicated in Fig. 4. The time constants of the RC network are selected so that the capacitors will become fully charged on each half-cycle of the highest frequency to be measured ($3.5 \text{ kc} + \text{maximum carrier deviation}$). To give the circuit a high order of stability, the switching tubes are supplied from a constant-current source so that the capacitors will always be charged to the same voltage. As a result, the pulses through the capacitors will all have the same charge.

Under these conditions the number of pulses passing through the capacitors per unit time is proportional to the frequency of the square waves applied to the network. Since the meter indicates the rectified value of these pulses and since all pulses have the same charge, the average d-c current through the meter is also proportional to the frequency of the square waves. A change in the frequency of the visual carrier, then, will cause a change in the frequency of the square wave and this in turn will cause a corresponding change in the meter current.

The visual deviation meter itself is calibrated in deviation from -1.5 kc to $+1.5 \text{ kc}$. In order that the meter can be calibrated with a zero-center scale in this manner, the pulse counter circuit is arranged so that the meter current at zero deviation of the carrier is cancelled by an equal and opposite bucking current. A net meter current is thus obtained only when the carrier is above or below its assigned frequency.

To insure the stability of the bucking current, it is derived from a divider network in the constant current source for the switching tubes. Should any change occur in the constant current source, then, it will

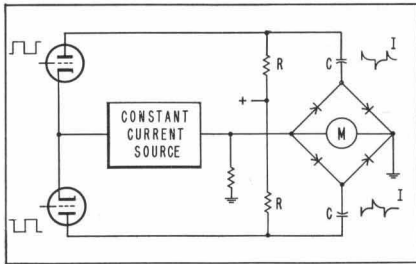

Fig. 4. Basic circuit of pulse counter in visual deviation meter circuit.

affect the bucking current as well as the current flowing through the capacitors. The circuit is thus self-compensating so that a high order of long-time stability is achieved.

The aural channel of the monitor is similar to but necessarily more elaborate than the visual channel.

A sample of the aural carrier from the transmitter is mixed with the multiplied master oscillator frequency to obtain a difference frequency that is equal to the separation of the carriers (4.5 megacycles) plus 3.5 kc. The 3.5 kc frequency results from the fact that the master oscillator frequency is selected so that, when multiplied, it will be 3.5 kc below the frequency of the visual carrier, as described earlier. Separate multipliers are used in the aural and visual channels for isolation reasons and both multipliers are well shielded.

The 4.5035-megacycle output of the first visual mixer is then mixed with the output of a 4.3535-megacycle crystal-controlled oscillator to obtain a difference frequency of 150 kc. This difference frequency contains whatever modulation is present on the aural carrier.

The difference frequency voltage is squared and applied to the pulse-counter type discriminator shown in Fig. 5. This counter is similar to the counter in the visual channel except that it contains circuitry that acts as a discriminator for the f-m modulation on the aural carrier. The discriminator is highly linear as indicated by the fact that the distortion in the entire monitor from all sources is less than 0.25% at 100% modulation at frequencies below the knee of the standard de-emphasis curve.

The manner in which the pulse-counter discriminator recovers the modulation signal from the aural carrier can be determined by considering that current pulses are flowing through the meter circuit at an average rate of 300 kc (each half-cycle of the 150 kc difference frequency). The instantaneous rate of the pulses, however, varies in accordance with the f-m modulation on the aural carrier. If, for example, the transmitter is modulated 100% (25 kc deviation) by a fixed frequency of 5000 cps, the current pulses through the meter will vary from 250 to 350 kc at a rate of 5000 cps. The audio component of this meter current variation is recovered by coupling the meter circuit to an amplifier by means of a low-impedance current-actuated network indicated by the transformer in Fig. 5. The meter itself is bypassed so that it will indicate only the average value of the current pulses.

The audio voltage obtained from the discriminator is amplified and applied to the percent modulation meter circuit and to the over-modulation lamp circuit. The point at which the overmodulation lamp

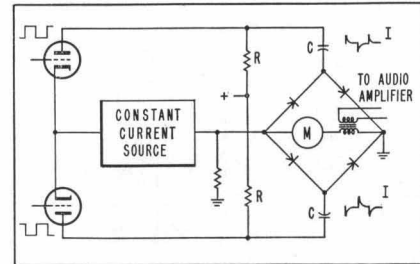

Fig. 5. Basic circuit of pulse-counter discriminator in aural deviation meter circuit.

flashes is adjustable from 50% to 120% modulation.

The percent modulation meter is operated from a peak-reading type voltmeter circuit whose time constant is adjusted so that the ballistic characteristics of the meter are in conformance with those of a standard VU meter. A panel switch is provided so that either positive or negative modulation swings can be measured.

Two separate audio outputs are provided by the output audio amplifier. One output is a high-level output which provides approximately 10 volts at low audio frequencies at 100% modulation. This output is primarily intended for use in making measurements of distortion and frequency response characteristics of the aural modulation. The output is provided from a high-quality system which has a response flat within 0.5 db from 50 to 15,000 cps. Distortion in the system is less than 0.25% at full output and noise is at least 65 db below full output.

The second audio output is provided from a balanced, ungrounded source. At low frequencies a maximum of 1 milliwatt is delivered to a 600-ohm load. This output is useful for aural monitoring of the program.

MONITOR ACCURACY

FCC regulations require that the carrier of the visual transmission shall be maintained within 1 kc and the carrier of the aural transmission within 4 kc of the assigned carrier frequencies. By comparison, the accuracy of the monitor has been conservatively established as being within 500 cps for ten days for the visual

BINDER AVAILABLE

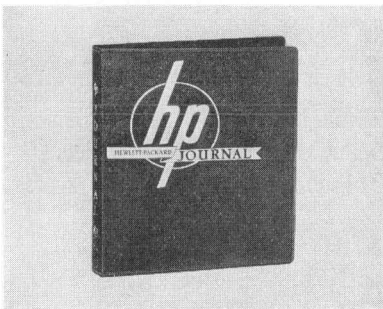

To keep intact your file of the Hewlett-Packard Journal, a new three-ring binder is now available. The binder is of good quality and is supplied in a dark blue color with a simple, smart design embossed on front cover and backbone. The three-ring metal is supplied with opening levers.

Price: one dollar, postpaid. Orders accepted only on a cash (or check) with order basis. Limited quantity available.

deviation section and within 1 kc for ten days for the aural deviation section.

The calibration of the pulse counter circuit in the aural deviation meter can be checked by means of a 150 kc crystal-controlled oscillator which is incorporated into the instrument. A panel control is provided for zeroing the counter circuit.

CARRIER NOISE MEASUREMENTS

The monitor is arranged to facilitate three types of carrier noise measurements: incidental f-m and incidental a-m, both on the aural carrier, and the effective total incidental f-m on the aural and visual carriers.

Incidental f-m can be measured readily, because the monitor provides a high-quality audio output which is driven from a highly linear discriminator. By connecting a sensitive vacuum-tube voltmeter across the audio output system, the f-m noise level of the aural carrier can be measured directly. The noise level of the monitor itself is at least 65 db below the output corresponding to 100% low-frequency modulation.

Measurements of incidental a-m on the aural carrier can be made by means of a special jack provided on the monitor. The measurement is made with the aid of a voltmeter in a manner similar to the measurement of incidental carrier f-m. Directions for this measurement are given in the equipment operating manual.

The third measurement, the effective total incidental f-m on the aural and visual carriers, is of importance in determining that the transmission does not result in an undue noise level in intercarrier type receivers. The measurement can be made by applying samples of both the aural and visual carriers to the aural carrier input connector on the monitor. Referring to Fig. 2, a panel control is provided to render the master oscillator inoperative. When samples of the two carriers are then

applied to the aural input connector, they will mix in the aural mixer to give a difference frequency of 4.5 megacycles which will contain the effective total incidental f-m of the aural and visual carriers. This incidental f-m will be detected in the pulse-counter discriminator. The resulting noise level can thus be measured at the output of the audio amplifier with a suitable voltmeter.

OTHER MEASUREMENTS

For convenience in installation and maintenance, a panel control is provided so that the panel meters can be switched to determine such quantities as the level of the visual and aural carrier samples supplied to the monitor, the activity of the master and separation oscillators, peaking of the mixers, and the accuracy of the aural deviation meter circuit. Measurements of the harmonic distortion and frequency response characteristics of the aural transmission can be made by connecting an *-hp-* Model 330 distortion analyzer to the audio output of the monitor while modulating the aural carrier from an *-hp-* Model 206A audio signal generator.

CONSTRUCTION

High quality components are used throughout the monitor. Power supply capacitors are oil-filled paper types. Only three electrolytic capacitors are used and two of these are non-critical meter by-pass capacitors. The third is hermetically sealed and meets JAN specifications. Precision wirewound resistors are used in all critical circuits. The monitor is blower-cooled and a renewable dust filter is included.

FCC APPROVAL PRACTICE

Present practice of the FCC is that it does not grant approval on TV monitors. However, complete tests have been made on the monitor to insure that its performance is in all respects at least equal to the *-hp-* Model 335B f-m monitor, which did have FCC approval.

GENERAL

Like all *-hp-* instruments, the Model 335E is available on a direct to the customer basis, and can be supplied in colors to match the transmitter color. Arrangements have also been made with most manufacturers of TV transmitters to permit the *-hp-* Model 335E TV monitor to be supplied along with the transmitter itself if desired.

The new Model 335E supersedes the Models 335C, D, and 336C, D aural and video carrier monitors. These monitors have been discontinued.

—Robert Grimm

SPECIFICATIONS -hp- MODEL 335E TV MONITOR

AURAL FREQUENCY MONITOR

Deviation Range: ± 6 kc to -6 kc mean frequency deviation.
Accuracy: Better than $\pm 1,000$ cps for at least 10 days.

AURAL MODULATION METER

Modulation Range: Meter reads full scale on modulation swing of 33.3 kc. Scale calibrated to 100% at 25 kc swing; 133% at 33.3 kc swing.
Accuracy: Within 5% modulation percentage over entire scale.
Meter Characteristics: Meter damped in accordance F.C.C. requirements. Reads peak value of modulation peak of duration between 40 and 90 milliseconds. Meter returns from full reading to 10% of full value within 500 to 800 milliseconds.
Frequency Response: Flat within $\pm 1/2$ db from 50 to 15,000 cps.

MODULATION PEAK INDICATOR

Peak Flash Range: From 50% to 120% modulation (25 kc = 100%).

VISUAL FREQUENCY MONITOR

Deviation Range: ± 1.5 kc to -1.5 kc mean frequency deviation.
Accuracy: Better than ± 500 cps for at least 10 days.

AUDIO OUTPUT

Frequency Range: 50 to 15,000 cps. Response flat within $\pm 1/2$ db. Equipped with standard 75 micro-second de-emphasis circuit.
Distortion: Less than 0.25% at 100% modulation.
Output Voltage: 10 volts into 20,000 ohms at 100% modulation at low frequencies.
Monitoring Output: 1 milliwatt into 600 ohms, balanced, at 100% modulation, at low frequencies.
Residual Noise: At least 65 db below output level corresponding to 100% modulation at low frequencies.

GENERAL

Frequency Range: Channels 2 to 83 inclusive, including offset channels.
R. F. Power Required: Approximately 2 watts.
External Meters: Provision made for use of external aural and visual carrier deviation meters and external aural modulation meter; also for external peak modulation lamp.
Size: 12 $1/4$ " high x 19" wide x 13" deep— for rack mounting only.
Power: 115 volts, 50/60 cps, 180 watts.
Price: \$1,950.00 f.o.b. Palo Alto, California
Data subject to change without notice.